

Troubleshooting

Suivi des évolutions

Indice	Date	Description de l'évolution	Auteur
0.0	05/01/2022	Création	FBR

Rédacteur	Responsable X	Qualité
FBR	FBR	FBR

1-Intro

The Z-Upgrade is made to LIMIT the wobbling, that mean virtually there will be some, at a certain point it is not quantifiable

The level of Z artifacts is link to the quality of the assembly

Actually the upgrade was release after a lot of test, and a lot of beta testers

So it works when everything is lined up

2-Potential issues in the system

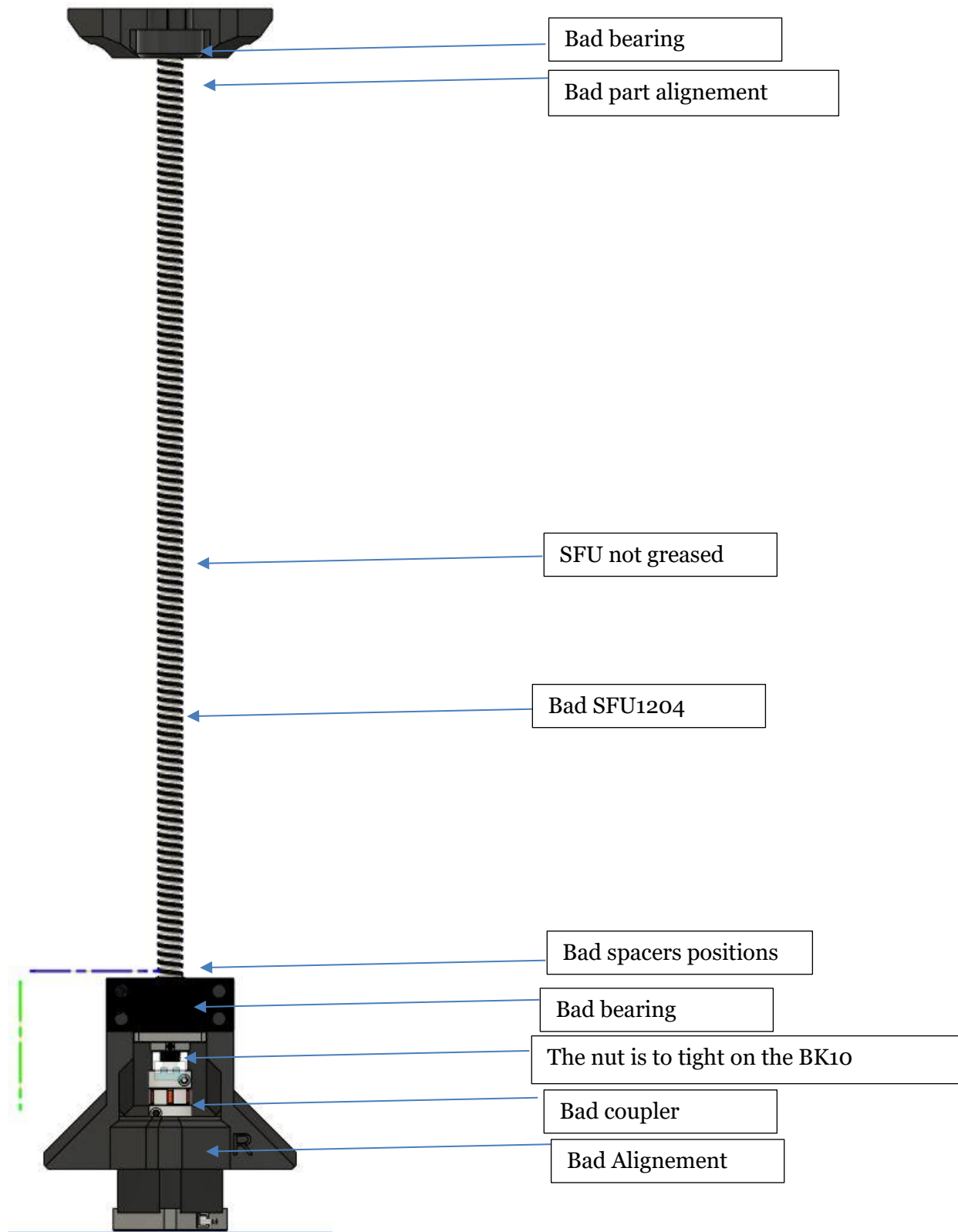

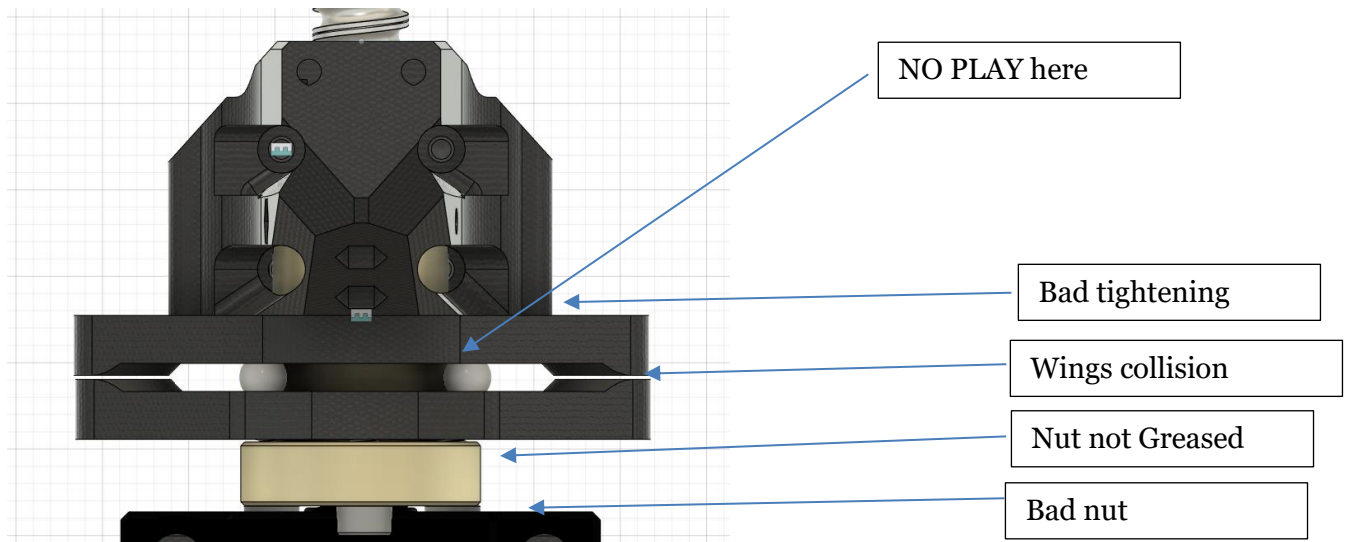

3-Tweaks and tips

- The lower part of the coupler SHOULD NOT touch the NEMA top
- The coupler can be faulty ; you can solve the issue by separating a bit the spider from each Aluminium parts

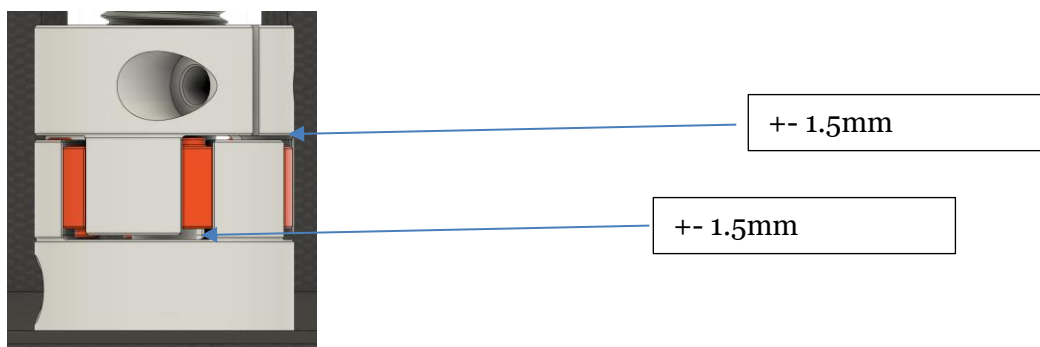

- Remove the circlip at the machined tip at the top of the retainer bearing
- Screws must be tightened
- A light ball lubrication can be made



Troubleshooting Z-Upgrade

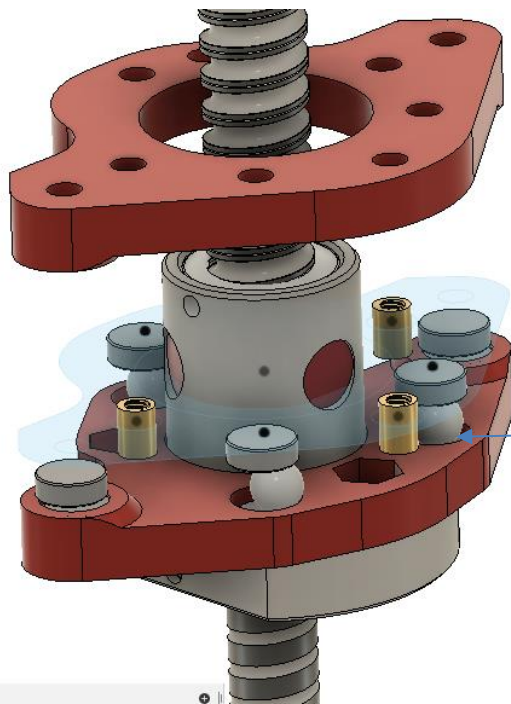

A drop of oil can help

-The alignment of the lower bracket and the retainer has to be perfect

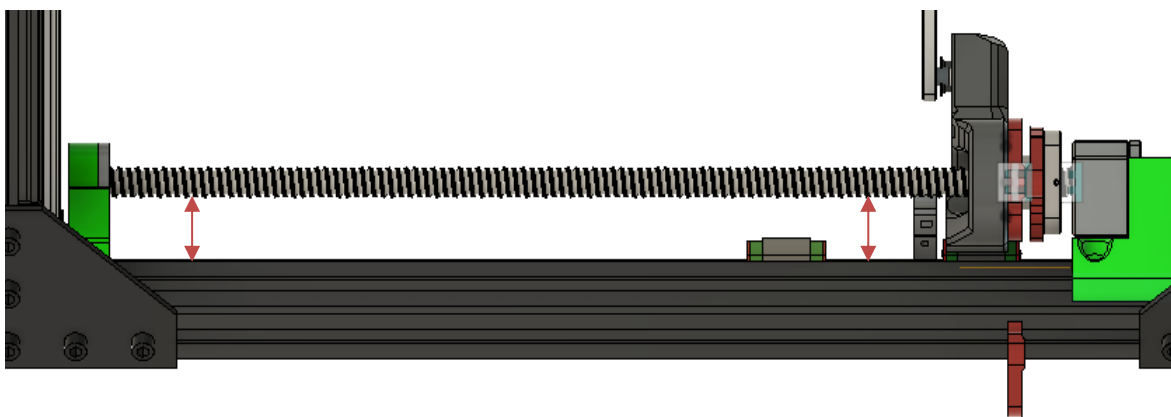

- The squariness of the frame can induce Z light wobbling ; try to frame the Frame the better you can



Troubleshooting Z-Upgrade

-Wings has to be parallele and no play should be found in it

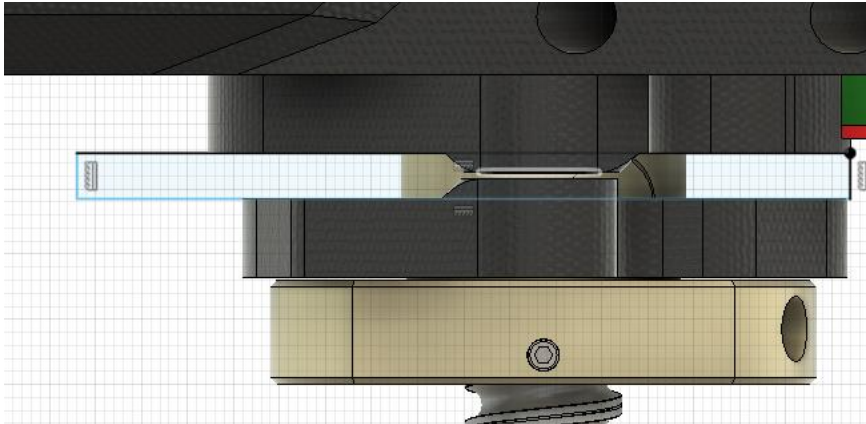

-Check if there is no collision to the wobble system and the SFU Nut in the free space arounds it

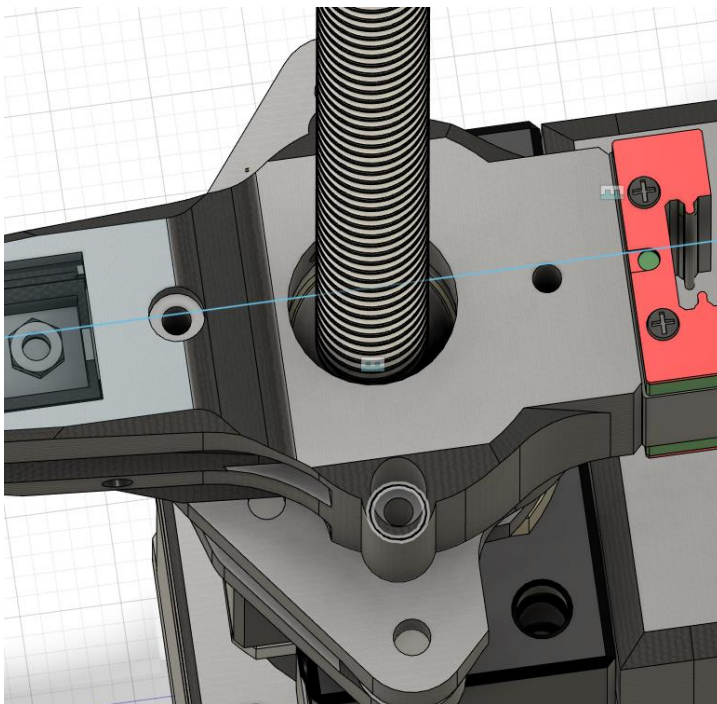

4-Last Checks :

- 1- **Check the tightening** of screws, nema etc
- 2- **Check the alignments**, in particular the RAIL / Screws
- 3- Hard point checks, the spindle can be rotate by hand without resistance
- 4- Cleanliness / lubrication checks (Rails + BS): Use a Hiwin GS04 lithium type grease or qualitative equivalent.



8-Disclaimer :

The system is designed to operate on a properly assembled Vcore. Even a slight mounting error can make it impossible to upgrade or issue during prints.

If the parts to be printed are made by the customer, check that the dimensions at the output of the printer are respected. : a bad dimension will block (+ -0.25mm) the assembly.

The machine will lose between 30 and 45mm of Z travel (depending on the screws used on the BK10s, the precision of the parts and the assembly) (32mm on the prototype), the same value for the 300, 400, 500.

This kit is an optional upgrade, intended for an informed public and having advanced experience, its assembly and / or its function and / or its quality of execution are the responsibility of the customer and are not guaranteed in public view by BRS-E. BRS-Engineering accepts no responsibility in the event of bad sourcing (bad quality and / or bad dimensions sfu), bad assembly by the customer, or bad assembly of the base Vcore.

The kit has proven its POC and POW in quality controls at BRS-E as well as at a beta test program, As is, the design works as expected

By purchasing the kit, or by having it done by BRS-Engineering, you accept the CGV as well as the previous disclaimer